



# MODEL 808Y

# CRYOGENIC NEEDLE VALVE

- reliable people.
- reliable solutions.
- reliable delivery.

**RATERMANN**  
Cryogenics

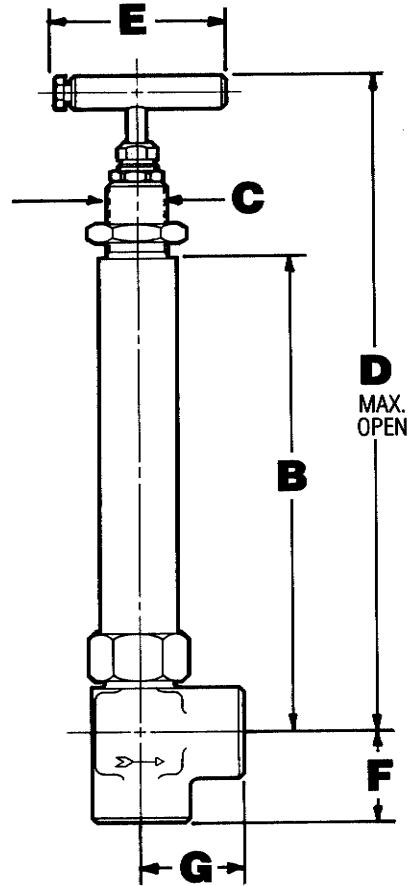
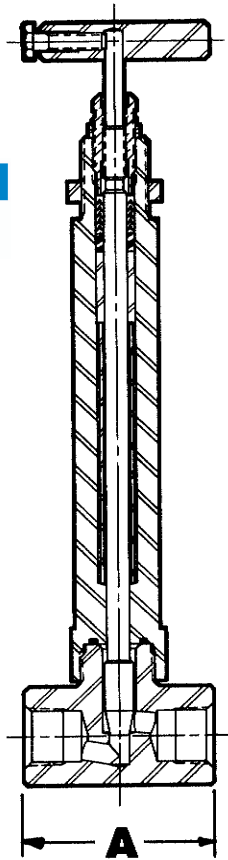

## SPECIFICATIONS

OPERATING PRESSURE: 1/4-1/2 10,000 PSI AT -370° F  
 3/4-1 6,000 PSI AT -370° F  
 TEMPERATURE RANGE: -370° F TO +450° F  
 FLOWING MEDIUM: LIQUID OXYGEN OR LIQUID NITROGEN  
 CLEANING: CLEANED AND PACKED FOR LOX PER APPLICABLE  
 SPECS, AS SPECIFIED; ADDITIONAL CHARGE

## BILL OF MATERIALS

QTY. ASSY	PART NAME	MATERIAL
1	BODY	STAINLESS STEEL TY 316
1	STEM	17-4 PH
1	GASKET	TEFLON
1	STOP NUT	STAINLESS STEEL TY 316
1	SPACER	STAINLESS STEEL TY 304
1	SLEEVE	STAINLESS STEEL TY 316
1	PACK SET	TEFLON* (Avail. KEL F)
1	PACK RING	TEFLON* (Avail. KEL F)
2	LOCK NUT	ST. STL. 300 SERIES
1	PACKING FOLLOWER	BRONZE AMPCO GR45
1	CAP SCREW	ST. STL. 300 SERIES
1	HANDLE	ST. STL. 300 SERIES

## DIMENSIONS

1/4	2	7	3/4	9 3/4	2 7/16	1 5/16	1 1/16	3/16	2 1/2 lb.
1/2	2 1/2	7 3/16	7/8	11	3 3/16	1 1/4	1 1/4	1 7/64	3 1/2 lb.
3/4	3	7 7/8	1 1/8	11 1/4	3 3/16	1 1/2	1 5/8	1 1/32	6 1/2 lb.
1	4 1/4	8	1 1/4	13 3/8	4 3/4	2 1/8	2 1/8	1 5/32	9 lb. 14 oz.
SIZE	A	B	C	D	E	F	G	ORIF.	WGT. LBS.

## ORDERING INSTRUCTIONS

PART NO. EXAMPLE: 808Y 0 5 4

BODY TYPE	MATERIAL	CONNECTIONS		PKG. OPTION
0	5	AISI 316	3 1/4 NPT	8 1/2 TUBE AN8
			4 1/4 TUBE AN 4	11 3/4 NPT
7	5	AISI 316	7 1/2 NPT	15 1 NPT
				16 1 TUBE AN16

When Ordering KEL F Pack Set and Pack Ring, Add Suffix K to Part No.

**RATERMANN**  
Cryogenics